

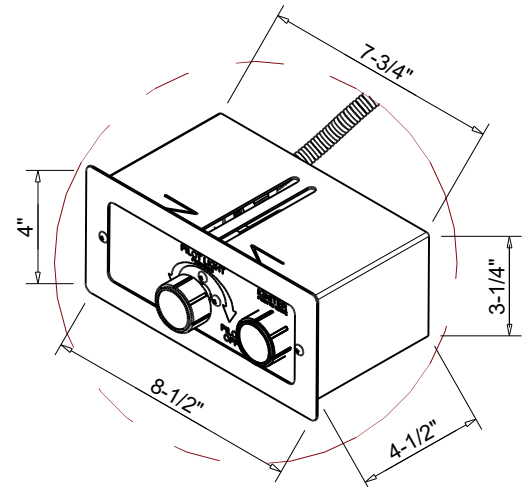

FIRE INSPIRED[™]

**CSA CERTIFIED-OUTDOOR USE ONLY
FOR COMMERCIAL AND RESIDENTIAL USE**

HEARTH PRODUCTS CONTROLS
2225 LYONS RD.
MIAMISBURG, OH 45342
TOLL FREE: 877.585.9800
PHONE: 937.436.9800
www.hpcfire.com

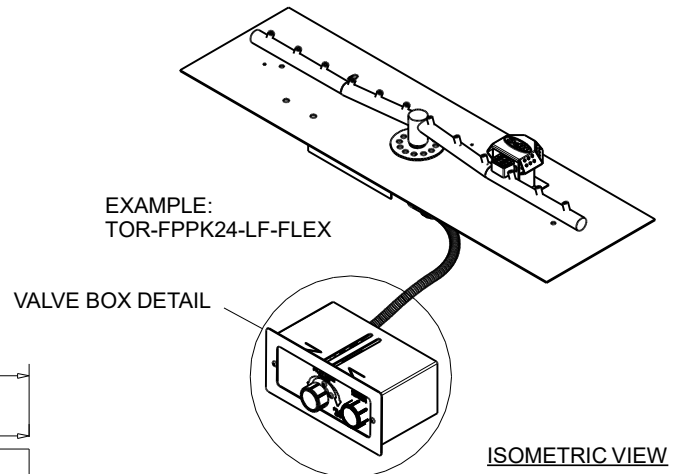
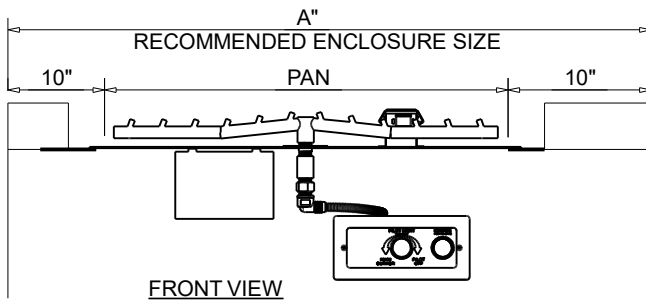
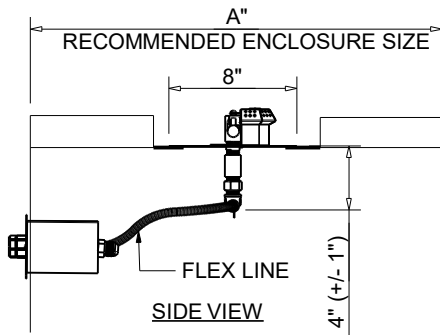

SPARK IGNITION BY AA BATTERY
MATERIAL: 304 STAINLESS STEEL

PART NUMBER	DIMENSION CHART			
	PAN	STANDARD BTU TORPEDO	A"	STND FLEX LINE LENGTH
TOR-FPPK24-LF-FLEX	27"	75K	44LX24W	36"
TOR-FPPK36-LF-FLEX	39"	115K	56LX24W	36"
TOR-FPPK48-LF-FLEX	51"	150K	68LX24W	36"
TOR-FPPK60-LF-FLEX	63"	175K	80LX24W	36"
TOR-FPPK72-LF-FLEX	75"	200K	92LX24W	36"
TOR-FPPK96-LF-FLEX	99"	250K	112LX24W	36"

NOTES:

- PROPER VENTING
 - ENCLOSURES:
 - For Fire Pit up to 200K BTU: Required minimum 2 vents, 18 sq.in. each on opposing sides.
 - For Fire Pit Inserts above 200K BTU: Required minimum 4 vents, 18 sq.in. each on opposing sides.
 - BOWLS (Copper, concrete or metal)
 - For Fire Pit inserts up to 90K: Required minimum 2 vents, 9 sq.in. each on opposing sides.
 - Or bowl to be raised above mounting surface minimum of 3/4" gap; Bowl to have a minimum of 6" diameter hole in bottom.
- GAS SUPPLY - FOR USE WITH FIXED PIPING SYSTEMS ONLY - NOT FOR USE WITH SMALL TANKS.
 - Natural Gas: Supply Pressure: Minimum: 3.5" W.C.; Maximum: 7.0" W.C.
 - LP Gas: Supply Pressure: Minimum: 8" W.C.; Maximum: 11.0" W.C.

IMPORTANT: Ensure any flex line that may be used from the permanent main fuel supply to the product is rated to the stated max btu of the product and certified to ANSI Z21.75*CSA 6.27.

- MODIFICATION OF PRODUCT WILL VOID ANY CERTIFICATION AND WARRANTY.
- FOLLOW ALL MANUFACTURER'S INSTALLATION INSTRUCTIONS AND LOCAL CODES.
- ALL DIMENSIONS ARE CONSIDERED TRUE AND REFLECT MANUFACTURER'S SPECIFICATIONS AS OF THE REVISION DATE.
- DO NOT SCALE DRAWING.
- THESE DRAWINGS ARE FOR SIZING AND PLANNING PURPOSES. ALL INFORMATION CONTAINED HEREIN WAS CURRENT AT THE TIME OF DEVELOPMENT. THE MANUFACTURER IS RESPONSIBLE FOR THE ACCURACY OF THE DRAWING.
- CONTRACTOR'S NOTE: FOR PRODUCT AND COMPANY INFORMATION VISIT www.CADdetails.com/info REFERENCE NUMBER 771-081

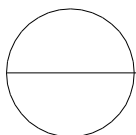

PUSH BUTTON/FLAME SENSING FIRE PIT INSERT - WITH FLEX LINE
LINEAR FLAT TROUGH PAN - FPPK

