

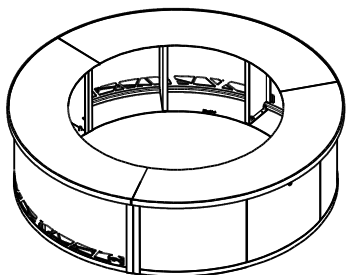

HEARTH PRODUCTS CONTROLS
 2225 LYONS RD.
 MIAMISBURG, OH 45342
 TOLL FREE: 877.585.9800
 PHONE: 937.436.9800
 www.hpcfire.com

Hearth Products Controls Co
 OPTIONAL ENCLOSURE FOR EVOLUTION 360 SERIES
 OUTDOOR USE ONLY
 FOR COMMERCIAL AND RESIDENTIAL USE
 BUILT OF LIGHT WEIGHT ALUMINUM



ASSEMBLED

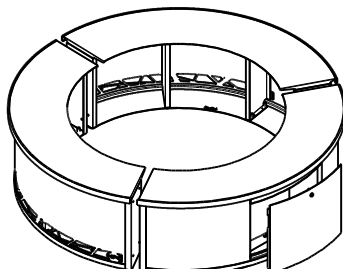

DISASSEMBLED

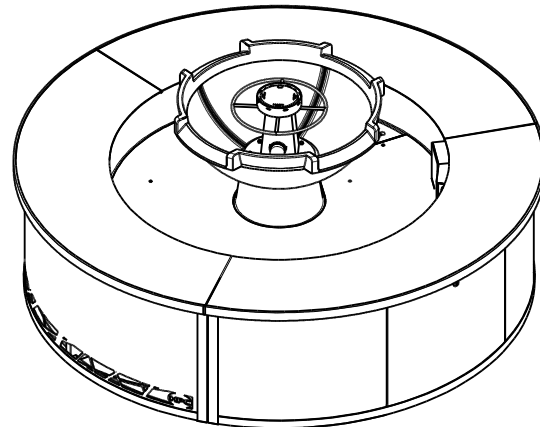

WPE-72ROUND-TB/CV WITH
 FOW52R-MONACO4BL-HWI-NG/VAC
 EXAMPLE

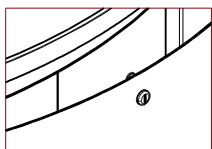

LOCKING KEY

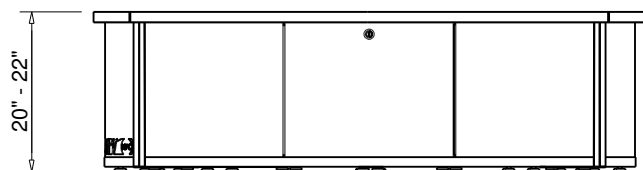

20" - 22"

FRONT VIEW

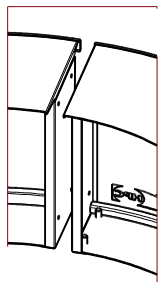

EASY ASSEMBLY

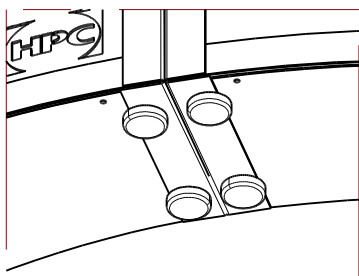

LEVELING FEET

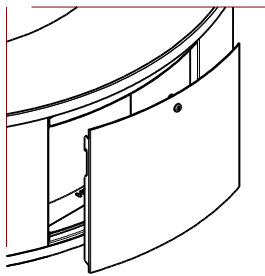

REMOVEABLE ACCESS
 PANEL

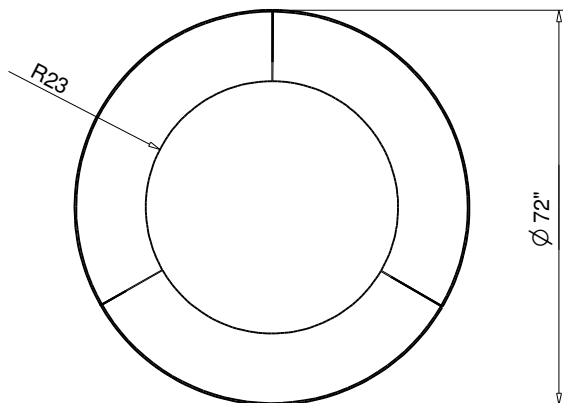

R23

Ø 72"

ASSEMBLED

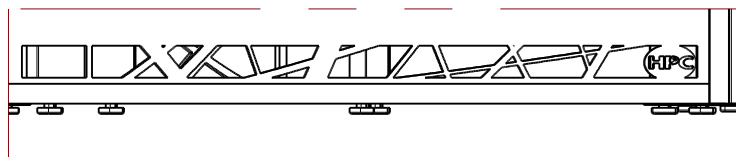

UNIQUE HPC VENTILATION

Notes:

1. FOR USE WITH FIXED PIPING SYSTEMS ONLY.
2. MODIFICATION OF PRODUCT WILL VOID ANY CERTIFICATION AND WARRANTY.
3. FOLLOW ALL MANUFACTURER INSTALLATION INSTRUCTIONS AND LOCAL CODES.
4. ALL DIMENSIONS ARE CONSIDERED TRUE AND REFLECT MANUFACTURER'S SPECIFICATIONS AS OF THE REVISION DATE.
5. DO NOT SCALE DRAWING.
6. THESE DRAWINGS ARE FOR SIZING AND PLANNING PURPOSES. ALL INFORMATION CONTAINED HEREIN WAS CURRENT AT THE TIME OF DEVELOPMENT. THE MANUFACTURE IS RESPONSIBLE FOR THE ACCURACY OF THE DRAWING.
7. CONTRACTOR'S NOTE: FOR PRODUCT AND COMPANY INFORMATION VISIT www.CADdetails.com/info REFERENCE NUMBER 771-057.

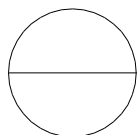

EVOLUTION 360
 OPTIONAL ENCLOSURE - PART NUMBER WPE-72ROUNDTB/CV